

RETAILER: This framesheet MUST BE provided to the end user.

Hello and thanks for picking up this lovely little number that we call the Macho King.

Built with what we feel is probably the greatest steel tubing in the history of the bicycle, Reynolds 853, and featuring ultra modern stuff like a 44mm headtube and tapered carbon fork.

This thing is perfect for those of you who like racing, but realize that you only really race like less than 1% of the time that you spend on your bike and you want to own a cross rig that you actually like putting in daily miles on.

Hope you love it,

Cheers,

All-City

⚠ WARNING: CYCLING CAN BE DANGEROUS. BICYCLE PRODUCTS SHOULD BE INSTALLED AND SERVICED BY A PROFESSIONAL MECHANIC. NEVER MODIFY YOUR BICYCLE OR ACCESSORIES. READ AND FOLLOW ALL PRODUCT INSTRUCTIONS AND WARNINGS INCLUDING INFORMATION ON THE MANUFACTURER'S WEBSITE. INSPECT YOUR BICYCLE BEFORE EVERY RIDE. ALWAYS WEAR A HELMET.

Additional Product and Safety Information can be found at the website: www.allcitycycles.com/safety.

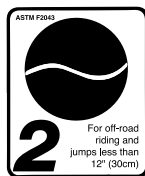

**Intended Use: Cyclocross
CONDITION 2**

Bikes are designed for riding Condition 1, plus smooth gravel roads and improved trails with moderate grades where the tires do not lose ground contact.

INTENDED For cyclocross riding, training and racing. Cyclocross involves riding on a variety of terrain and surfaces including dirt or mud surfaces. Cyclocross bikes also work well for all-weather rough road riding and commuting.

NOT INTENDED For off-road or mountain bike use, or jumping. Cyclocross riders and racers dismount before reaching an obstacle, carry their bike over the obstacle and then remount. Cyclocross bikes are not intended for mountain bike use. The relatively larger road bike-size wheels are faster than the smaller mountain bike wheels, but not as strong.

| MAXIMUM WEIGHT LIMIT (lb/kg) | Rider | Luggage* | Total |
|------------------------------|---------|----------|---------|
| | 300/136 | 30/13.6 | 330/150 |

*Seat Bag/Handlebar Bag Only

Frameset Compatibility

| | |
|------------------------|---|
| Tubing | Reynolds 853 tubing, double-butt down, top, and seat tubes. 4130 tubing externally tapered, ovalized, and dimpled chainstays, tapered seatstays |
| Fork | Whisky No.7 Carbon Fork |
| Dropouts | All-City Signature Vertical Disc |
| Braze-Ons | Water bottle mounts on seat tube and downtube with reinforcement plates, hidden fender mounts, front derailleur pulley mount |
| Seatpost Diameter | 27.2mm |
| Front Derailleur Clamp | 28.6mm |
| Headset | SHIS upper ZS44/28.6mm, SHIS lower EC44/40mm crown race 39.7mm, clamp diameter 28.6mm |
| Bottom Bracket Shell | 68mm, English threading |
| Brake Mounts | I.S. 51 disc mounts |
| Rear Spacing | 135mm |
| Tire Clearance | 700c x 38mm with lots of mud clearance |

For complete bike specs and reasoning behind our component choices go to www.allcitycycles.com.

Geometry Chart

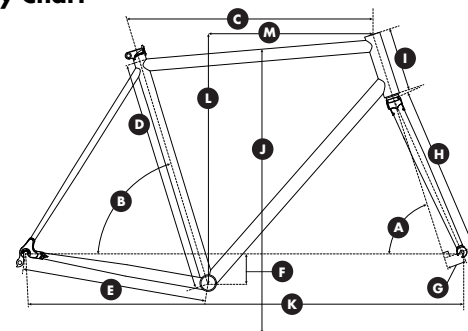

| Size | 46cm | 49cm | 52cm | 55cm | 58cm | 61cm |
|-----------------------|-------|-------|--------|--------|--------|--------|
| A Headtube Angle | 70.5° | 71° | 71.5° | 72° | 72.5° | 72.5° |
| B Seat Tube Angle | 74° | 73.5° | 73° | 73° | 72.5° | 72.5° |
| C Toptube Length | 520 | 535 | 550 | 565 | 585 | 605 |
| D Seat Tube Length | 460 | 490 | 520 | 550 | 580 | 610 |
| E Chainstay Length | 415 | 420 | 420 | 420 | 420 | 420 |
| F Bottom Bracket Drop | 70 | 70 | 70 | 70 | 70 | 70 |
| G Fork Offset | 45 | 45 | 45 | 45 | 45 | 45 |
| H Total Fork Length | 395 | 395 | 395 | 395 | 395 | 395 |
| I Headtube Length | 95 | 110 | 130 | 150 | 175 | 200 |
| J Standover | 756 | 778 | 802 | 827 | 853 | 880 |
| K Wheelbase | 985.7 | 997.4 | 1003.6 | 1014.4 | 1024.2 | 1044.2 |
| L Stack | 526.2 | 542.2 | 563.0 | 583.9 | 609.6 | 633.4 |
| M Reach | 369.1 | 374.4 | 377.9 | 386.5 | 392.8 | 405.3 |

Measurements in mm unless noted.



Care and Maintenance

Keep your frame clean. Dirt and road grime lead to oxidation and fading of the finish, and they make it hard to do a thorough inspection. Dirt will accelerate any abrasion of the paint that comes from rubbing, such as places where the cable housing touches the frame. In extreme cases, this type of abrasion could remove frame material.

When your bicycle is not being ridden, store it where it will be protected from rain, snow, sun, etc. Rain or snow may cause the metal on your frame to corrode. We recommend applying J.P. Weigle's Frame Saver to the inside of the tubes before the frame is assembled into a bike.

If your bicycle was exposed to moisture during a ride, thoroughly dry the bicycle before storing it. If water got inside the frame, tilt the bicycle to drain the water. If necessary, remove the seatpost and turn the bicycle upside down. This is especially critical if there is a large amount of water inside. If water freezes inside your frame, the expansion of the ice can crack and rupture the structure.

Before storing your bicycle for an extended period of time, clean and lubricate the frame with a frame wax, polish, or protectant. Do not store the bicycle near electric motors, as ozone from motors destroys paint. Before riding the bicycle again, follow the pre-ride checklist to be certain it is in good working order.

Inspection

Before every ride carefully inspect your frame for signs of fatigue. If any frame part shows signs of damage or fatigue, consult your dealer or replace the frame before riding the bicycle.

⚠ WARNING: An improperly modified frame, fork, or component can cause you to lose control and fall. NEVER MODIFY YOUR FRAMESET.

⚠ WARNING: Attaching incompatible clamping devices to a fork can lead to fork breakage, causing a loss of control. If you are not sure if a device is compatible, consult your dealer.

Serial Number

Write it down now! Seriously. It's important if your bike is stolen or for questions about your frame. The number is stamped into the bottom of the bottom bracket shell.

Limited Warranty

This All-City® product is warranted against defects in materials and workmanship for three years from the date of retail purchase of the product, subject to the limitations detailed below. Save your dated receipt for proof of purchase.

This warranty does NOT cover the following:

- Damage due to improper assembly or follow-up maintenance or lack of skill, competence or experience of the user or assembler
- Products that have been modified, neglected, used in competition or for commercial purposes, misused or abused, involved in accidents or anything other than normal use
- Installation of components, parts or accessories not originally intended for or compatible with All-City products
- Damage or deterioration to the paint, surface finish, aesthetics or appearance of the product
- Normal wear and tear
- Labor required to remove and/or refit and re-adjust the product within the bicycle assembly

This limited warranty is expressly limited to the repair or replacement of a defective product, at the option of All-City Cycles, and is the sole remedy of the warranty. This limited warranty applies only to the original purchaser of the All-City product and is not transferrable. This warranty applies only to products purchased through an authorized dealer or distributor. In no event shall All-City Cycles be liable for any loss, inconvenience or damage, whether direct, incidental, consequential, or otherwise resulting from breach of any express or implied warranty or condition, of merchantability, fitness for a particular purpose, or otherwise with respect to our products except as set forth herein.

This limited warranty gives the consumer specific legal rights, and those rights and other rights may vary from place to place. This limited warranty does not affect your statutory rights.

TO THE EXTENT NOT PROHIBITED BY LAW, THESE WARRANTIES ARE EXCLUSIVE AND THERE ARE NO OTHER EXPRESS OR IMPLIED WARRANTIES OR CONDITIONS INCLUDING WARRANTIES OR CONDITIONS OF MERCHANTABILITY AND FITNESS FOR A PARTICULAR PURPOSE.

Warranty Process

We will happily back up our products if there is a problem that is our fault. If you and your shop think your All-City product is worthy of a warranty inspection, please return the product to the original place of purchase, accompanied by a sales receipt.

Contact Us

Questions, comments, anecdotes, build pics and hipster jokes can and should be directed to:

All-City Cycles
6400 West 105th Street
Minneapolis, MN 55438

Phone: 1.888.4AC.BIKE
Web: www.allcitycycles.com
E-mail: info@allcitycycles.com

