

Hey, thanks for supporting All-City and buying our stuff. We really appreciate it, and hope that you get years of use and enjoyment from your purchase. If there's ever anything we can do for you, let us know.

Cheers

**⚠ WARNING:** CYCLING CAN BE DANGEROUS. BICYCLE PRODUCTS SHOULD BE INSTALLED AND SERVICED BY A PROFESSIONAL MECHANIC. NEVER MODIFY YOUR BICYCLE OR ACCESSORIES. READ AND FOLLOW ALL PRODUCT INSTRUCTIONS AND WARNINGS INCLUDING INFORMATION ON THE MANUFACTURER'S WEBSITE. INSPECT YOUR BICYCLE BEFORE EVERY RIDE. ALWAYS WEAR A HELMET.

## Compatibility & Intended Use

The All-City Shot Collar is available in multiple sizes. Check with your frame manufacturer for the correct size.

**⚠ WARNING:** Incorrectly sized seatpost collars could cause the seatpost to slip while riding and lead to serious injury.

**NOTE:** Make sure that your frame seat tube is free of any burrs or peeled paint. It may be necessary to gently sand the frame to achieve a smooth finish.

## Tools:

4mm Allen wrench

Torque wrench

Assembly compound

## Shot Collar Installation

1. Apply a thin layer of assembly compound to the top of your seat tube.
2. Slide the collar onto your frame. The slot in the collar should face towards the back of the bike, regardless of frame slot location, and the inner lip of the collar should sit flush on top of the seat tube.
3. Apply assembly compound to seatpost and inside of seat tube and insert into frame.  
**⚠ WARNING:** The seatpost must be inserted into the frame below the minimum insertion line marked on the seatpost.
4. Tighten the M5 bolt with a 4mm Allen wrench to 3–5Nm or manufacturer's recommended frame/post torque setting, whichever is lowest.

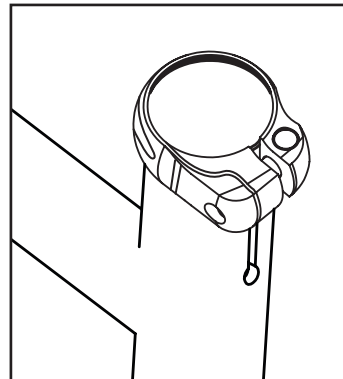

## Ongoing Maintenance

Periodically make sure the Shot Collar is tightened to the proper torque.

## Limited Warranty

This product is warranted against defects in materials and workmanship for 1 year from the date of retail purchase of the product, subject to the limitations detailed below. Save your dated receipt for proof of purchase.

This warranty does NOT cover the following:

- Damage due to improper assembly or follow-up maintenance or lack of skill, competence or experience of the user or assembler
- Products that have been modified, neglected, used in competition or for commercial purposes, misused or abused, involved in accidents or anything other than normal use

- Installation of components, parts or accessories not originally intended for or compatible with product as sold
- Damage or deterioration to the paint, surface finish, aesthetics or appearance of the product
- Normal wear and tear
- Labor required to remove and/or refit and re-adjust the product within the bicycle assembly

This limited warranty is expressly limited to the repair or replacement of the original product, at the option of All-City Cycles, and is the sole remedy of the warranty. This limited warranty applies only to the original purchaser of the All-City Cycles product and is not transferable. This warranty applies only to products purchased through an authorized dealer or distributor. In no event shall All-City Cycles be liable for any loss, inconvenience or damage, whether direct, incidental, consequential, or otherwise resulting from breach of any express or implied warranty or condition, of merchantability, fitness for a particular purpose, or otherwise with respect to All-City Cycles products except as set forth herein.

This warranty gives the consumer specific legal rights, and those rights and other rights may vary from place to place. This warranty does not affect your statutory rights.

TO THE EXTENT NOT PROHIBITED BY LAW, THESE WARRANTIES ARE EXCLUSIVE AND THERE ARE NO OTHER EXPRESS OR IMPLIED WARRANTIES OR CONDITIONS INCLUDING WARRANTIES OR CONDITIONS OF MERCHANTABILITY AND FITNESS FOR A PARTICULAR PURPOSE.

## Other Products

Check our website for the full range of All-City bikes, frames, parts and accessories.

## Contact Us

Questions, comments, anecdotes, build pics and hipster jokes can and should be directed to:

All-City Cycles

6400 West 105th Street  
Minneapolis, MN 55438

Phone: 1.888.4AC.BIKE

Web: [www.allcitycycles.com](http://www.allcitycycles.com)

E-mail: [info@allcitycycles.com](mailto:info@allcitycycles.com)