

The Airwolf is the most modern fixed gear freestyle frame out there. It's built around 26" wheels, has a positive BB that allows double peg grinds, and a mid bottom bracket. It clears a 2.3 tire with the wheel slammed fully forward in the dropouts, and was designed to be used with our venerable Dropout fork.

This is the future of 26" fixed.

⚠ WARNING: CYCLING CAN BE DANGEROUS. BICYCLE PRODUCTS SHOULD BE INSTALLED AND SERVICED BY A PROFESSIONAL MECHANIC. NEVER MODIFY YOUR BICYCLE OR ACCESSORIES. READ AND FOLLOW ALL PRODUCT INSTRUCTIONS AND WARNINGS INCLUDING INFORMATION ON THE MANUFACTURER'S WEBSITE. INSPECT YOUR BICYCLE BEFORE EVERY RIDE. ALWAYS WEAR A HELMET.

Additional Product and Safety Information can be found at the website: www.allcitycycles.com/safety.

Intended Use

Dirt Jump

CONDITION 5



Bikes designed for jumping, hucking, high speeds, or aggressive riding on rougher surfaces, or landing on flat surfaces. However, this type of riding is extremely hazardous and puts unpredictable forces on a bicycle which may overload the frame, fork, or parts. If you choose to ride in Condition 5 terrain, you should take appropriate safety precautions such as more frequent bike inspections and replacement of equipment. You should also wear comprehensive safety equipment such as a full-face helmet, pads, and body armor.

INTENDED For man-made dirt jumps, ramps, skate parks with predictable obstacles and terrain where riders need and use skill and bike control, rather than suspension. Dirt Jumping bikes are used much like heavy-duty BMX bikes. A Dirt Jumping bike does not give you skills to jump.

NOT INTENDED For terrain, drop offs or landings where large amounts of suspension travel are needed to help absorb the shock of landing and help maintain control.

TRADE OFF Dirt Jumping bikes are lighter and more nimble than Freeride bikes, but they have no rear suspension and the suspension travel in the front is much shorter.

MAXIMUM WEIGHT LIMIT (lb/kg)	Rider	Luggage	Total
	300/136	0	300/136

Frameset Compatibility

Head Set	Campy 45/45° standard
Dropouts	14mm w/spacers for 10mm compatibility
Bottom Bracket	Mid
Rear Spacing	120mm
Seatpost	27.2mm
Seat Collar	30.0mm
Brakes	Long-reach road
Max Chainring	37t
Frame Weight	5.5 lb

For complete bike specs and reasoning behind our component choices go to www.allcitycycles.com.

Geometry Chart

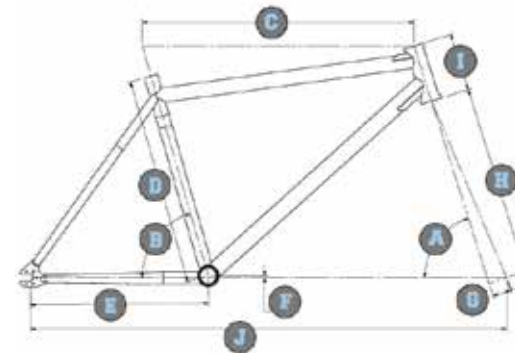

AIRWOLF

Size	Small	Medium	Large
A Headtube Angle	72.5°	72.5°	72.5°
B Seat Tube Angle	74.0	74.0	74.0
C Top tube Length	572	588	603
D Seat Tube Length	400	450	500
E Chainstay Length	385	385	385
F Bottom Bracket Drop	-4	-4	-4
G Fork Offset	30	30	30
H Total Fork Length	410	410	410
I Headtube Length	110	125	140
J Wheelbase	1004	1020	1035

Measurements in mm unless noted.

Care and Maintenance

Keep your frame clean. Dirt and road grime lead to oxidation and fading of the finish, and they make it hard to do a thorough inspection. Dirt will accelerate any abrasion of the paint that comes from rubbing, such as places where the cable housing touches the frame. In extreme cases, this type of abrasion could remove frame material.

When your bicycle is not being ridden, store it where it will be protected from rain, snow, sun, etc. Rain or snow may cause the metal on your frame to corrode. We recommend applying J.P. Weigle's Frame Saver to the inside of the tubes before the frame is assembled into a bike.

If your bicycle was exposed to moisture during a ride, thoroughly dry the bicycle before storing it. If water got inside the frame, tilt the bicycle to drain the water. If necessary, remove the seatpost and turn the bicycle upside down. This is especially critical if there is a large amount of water inside. If water freezes inside your frame, the expansion of the ice can crack and rupture the structure.

Before storing your bicycle for an extended period of time, clean and lubricate the frame with a frame wax, polish, or protectant. Do not store the bicycle near electric motors, as ozone from motors destroys paint. Before riding the bicycle again, follow the pre-ride checklist to be certain it is in good working order.

Inspection

Before every ride carefully inspect your frame for signs of fatigue. If any frame part shows signs of damage or fatigue, consult your dealer or replace the frame before riding the bicycle.

⚠ WARNING: An improperly modified frame, fork, or component can cause you to lose control and fall. NEVER MODIFY YOUR FRAMESET.

⚠ WARNING: Attaching incompatible clamping devices to a fork can lead to fork breakage, causing a loss of control. If you are not sure if a device is compatible, consult your dealer.

Serial Number

Write it down now! Seriously. It's important if your bike is stolen or for questions about your frame. The number is stamped into the bottom of the bottom bracket shell.

Limited Warranty

This All-City® product is warranted against defects in materials and workmanship for three years from the date of retail purchase of the product, subject to the limitations detailed below. Save your dated receipt for proof of purchase.

This warranty does NOT cover the following:

- Damage due to improper assembly or follow-up maintenance or lack of skill, competence or experience of the user or assembler
- Products that have been modified, neglected, used in competition or for commercial purposes, misused or abused, involved in accidents or anything other than normal use
- Installation of components, parts or accessories not originally intended for or compatible with bicycle as sold
- Damage or deterioration to the paint, surface finish, aesthetics or appearance of the product
- Normal wear and tear
- Labor required to remove and/or refit and re-adjust the product within the bicycle assembly

This limited warranty is expressly limited to the repair or replacement of a defective product, at the option of All-City Cycles, and is the sole remedy of the warranty. This limited warranty applies only to the original purchaser of the All-City product and is not transferrable. This warranty applies only to products purchased through an authorized dealer or distributor. In no event shall All-City Cycles be liable for any loss, inconvenience or damage, whether direct, incidental, consequential, or otherwise resulting from breach of any express or implied warranty or condition, of merchantability, fitness for a particular purpose, or otherwise with respect to our products except as set forth herein.

This limited warranty gives the consumer specific legal rights, and those rights and other rights may vary from place to place. This limited warranty does not affect your statutory rights.

TO THE EXTENT NOT PROHIBITED BY LAW, THESE WARRANTIES ARE EXCLUSIVE AND THERE ARE NO OTHER EXPRESS OR IMPLIED WARRANTIES OR CONDITIONS INCLUDING WARRANTIES OR CONDITIONS OF MERCHANTABILITY AND FITNESS FOR A PARTICULAR PURPOSE.

Warranty Process

We will happily back up our products if there is a problem that is our fault. If you and your shop think your All-City product is worthy of a warranty inspection, please return the product to the original place of purchase, accompanied by a sales receipt.

Contact Us

Questions, comments, anecdotes, build pics and hipster jokes can and should be directed to:

All-City Cycles
6400 West 105th Street
Minneapolis, MN 55438

Phone: 1.888.4AC.BIKE
Web: www.allcitycycles.com
E-mail: info@allcitycycles.com

